

SALES DRAWING

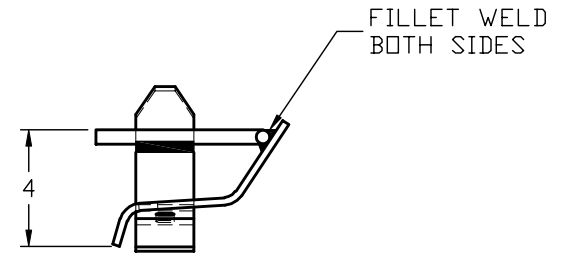
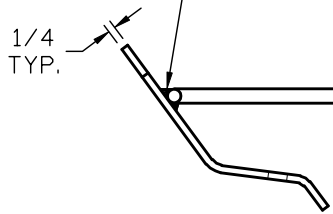
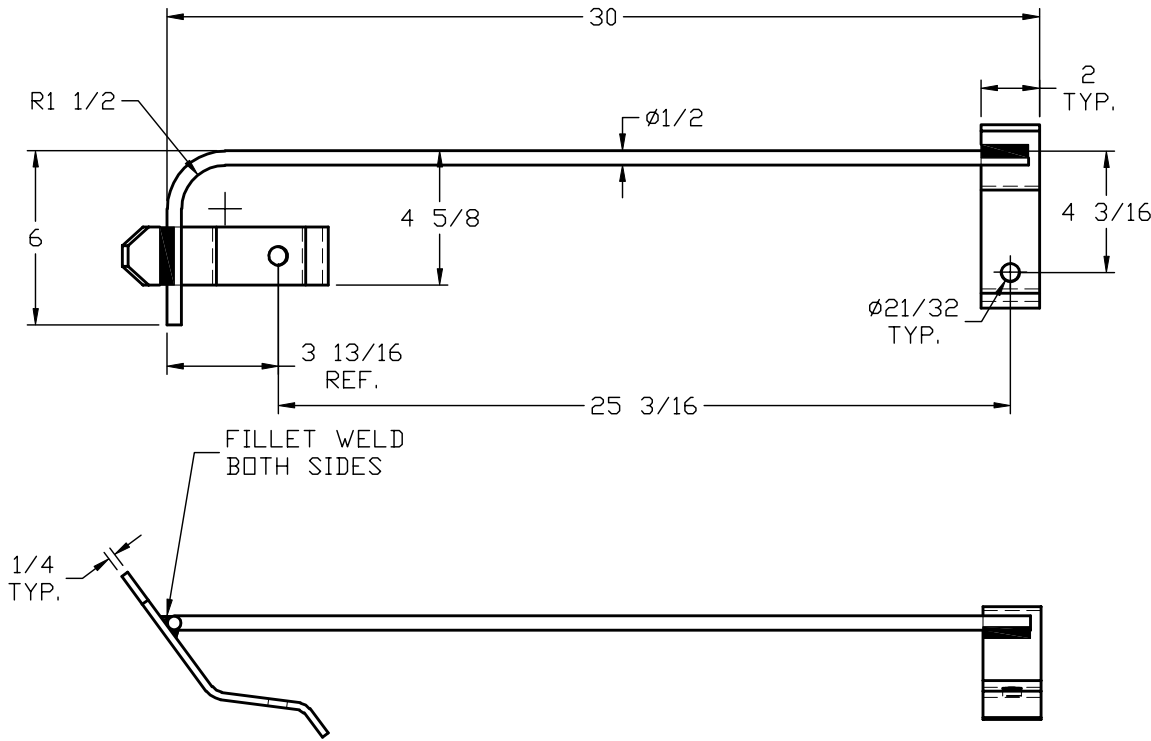

SALES DRAWING

UNLESS OTHERWISE SPECIFIED DIMENSIONAL TOLERANCES		<table border="1"> <tr> <td>A</td> <td>CHL</td> <td>8-5-03</td> <td>UPDATED DRAWING TO MATCH PART</td> </tr> <tr> <td>REV</td> <td>BY</td> <td>DATE</td> <td>DESCRIPTION</td> </tr> </table>		A	CHL	8-5-03	UPDATED DRAWING TO MATCH PART	REV	BY	DATE	DESCRIPTION												
A	CHL	8-5-03	UPDATED DRAWING TO MATCH PART																				
REV	BY	DATE	DESCRIPTION																				
<table border="1"> <tr> <td>FRACTIONAL</td> <td>±1/16</td> </tr> <tr> <td>X.XX</td> <td>±0.03</td> </tr> <tr> <td>X.XXX</td> <td>±0.015</td> </tr> <tr> <td>ANGULAR</td> <td>±1°</td> </tr> </table>		FRACTIONAL	±1/16	X.XX	±0.03	X.XXX	±0.015	ANGULAR	±1°	<table border="1"> <tr> <td colspan="2" style="text-align: center;">SALCO PRODUCTS, INC.</td> <td style="text-align: right;">20</td> </tr> <tr> <td>DRAWN BY: JDA</td> <td>CHKD BY:</td> <td>SCALE: 1:2</td> </tr> <tr> <td colspan="2">MATERIAL: 1018 CARBON STEEL</td> <td>APPROVAL DATE: 1-20-93</td> </tr> <tr> <td colspan="3">PART NAME: BAR CHAIN</td> </tr> </table>		SALCO PRODUCTS, INC.		20	DRAWN BY: JDA	CHKD BY:	SCALE: 1:2	MATERIAL: 1018 CARBON STEEL		APPROVAL DATE: 1-20-93	PART NAME: BAR CHAIN		
FRACTIONAL	±1/16																						
X.XX	±0.03																						
X.XXX	±0.015																						
ANGULAR	±1°																						
SALCO PRODUCTS, INC.		20																					
DRAWN BY: JDA	CHKD BY:	SCALE: 1:2																					
MATERIAL: 1018 CARBON STEEL		APPROVAL DATE: 1-20-93																					
PART NAME: BAR CHAIN																							
<small>THIS IS THE PROPERTY OF SALCO PRODUCTS, INC. CONTAINING PROPRIETARY INFORMATION, AND MUST NOT BE COPIED, REPRODUCED, OR USED IN WHOLE OR IN PART WITHOUT THE WRITTEN PERMISSION OF SALCO PRODUCTS, INC.</small>		<table border="1"> <tr> <td>PROJECT #:</td> <td>PROTOTYPE (AND) DATE:</td> <td>APPROVED FOR PRODUCTION:</td> </tr> <tr> <td>DRAWING #:</td> <td>PART #:</td> <td>JDA</td> </tr> </table>		PROJECT #:	PROTOTYPE (AND) DATE:	APPROVED FOR PRODUCTION:	DRAWING #:	PART #:	JDA														
PROJECT #:	PROTOTYPE (AND) DATE:	APPROVED FOR PRODUCTION:																					
DRAWING #:	PART #:	JDA																					
<small>THIRD ANGLE PROJECTION</small> 		<table border="1"> <tr> <td>D5233</td> <td>SCB111</td> </tr> </table>		D5233	SCB111																		
D5233	SCB111																						